

# Current Transducer LA 55-P

$$I_{PN} = 50 \text{ A}$$

For the electronic measurement of currents: DC, AC, pulsed..., with a galvanic isolation between the primary circuit (high power) and the secondary circuit (electronic circuit).



16019

## Electrical data

$I_{PN}$	Primary nominal current rms	50	A					
$I_{PM}$	Primary current, measuring range	0 .. $\pm 70$	A					
$R_M$	Measuring resistance @	$T_A = 70^\circ\text{C}$		$T_A = 85^\circ\text{C}$				
		$R_{Mmin}$	$R_{Mmax}$	$R_{Mmin}$	$R_{Mmax}$			
		with $\pm 12 \text{ V}$	@ $\pm 50 \text{ A}_{max}$	10	100	60	95	$\Omega$
			@ $\pm 70 \text{ A}_{max}$	10	50	60 <sup>1)</sup>	60 <sup>1)</sup>	$\Omega$
	with $\pm 15 \text{ V}$	@ $\pm 50 \text{ A}_{max}$	50	160	135	155	$\Omega$	
		@ $\pm 70 \text{ A}_{max}$	50	90	135 <sup>2)</sup>	135 <sup>2)</sup>	$\Omega$	
$I_{SN}$	Secondary nominal current rms	50	mA					
$K_N$	Conversion ratio	1 : 1000						
$V_C$	Supply voltage ( $\pm 5 \%$ )	$\pm 12 \dots 15$	V					
$I_C$	Current consumption	10 (@ $\pm 15 \text{ V}$ ) + $I_S$	mA					
$V_d$	Rms voltage for AC isolation test, 50 Hz, 1 min	2.5	kV					

## Features

- Closed loop (compensated) current transducer using the Hall effect
- Printed circuit board mounting
- Isolated plastic case recognized according to UL 94-V0.

## Advantages

- Excellent accuracy
- Very good linearity
- Low temperature drift
- Optimized response time
- Wide frequency bandwidth
- No insertion losses
- High immunity to external interference
- Current overload capability.

## Accuracy - Dynamic performance data

$X$	Accuracy @ $I_{PN}$ , $T_A = 25^\circ\text{C}$	@ $\pm 15 \text{ V} (\pm 5 \%)$	$\pm 0.65$	%
		@ $\pm 12 \dots 15 \text{ V} (\pm 5 \%)$	$\pm 0.90$	%
$e_L$	Linearity error		< 0.15	%
$I_O$	Offset current @ $I_p = 0$ , $T_A = 25^\circ\text{C}$	Typ		Max
				$\pm 0.2$ mA
$I_{OM}$	Magnetic offset current <sup>3)</sup> @ $I_p = 0$ and specified $R_M$ after an overload of $3 \times I_{PN}$			$\pm 0.3$ mA
$I_{OT}$	Temperature variation of $I_O$	0°C .. + 70°C	$\pm 0.1$	$\pm 0.5$ mA
		- 25°C .. + 85°C	$\pm 0.1$	$\pm 0.6$ mA
$t_{ra}$	Reaction time @ 10 % of $I_{PN}$		< 500	ns
$t_r$	Response time to 90 % of $I_{PN}$ step		< 1	$\mu\text{s}$
$di/dt$	di/dt accurately followed		> 200	A/ $\mu\text{s}$
<b>BW</b>	Frequency bandwidth (- 1 dB)		DC .. 200	kHz

## Applications

- AC variable speed drives and servo motor drives
- Static converters for DC motor drives
- Battery supplied applications
- Uninterruptible Power Supplies (UPS)
- Switched Mode Power Supplies (SMPS)
- Power supplies for welding applications.

## General data

$T_A$	Ambient operating temperature	- 25 .. + 85	$^\circ\text{C}$
$T_S$	Ambient storage temperature	- 40 .. + 90	$^\circ\text{C}$
$R_S$	Secondary coil resistance @	$T_A = 70^\circ\text{C}$	80 $\Omega$
		$T_A = 85^\circ\text{C}$	85 $\Omega$
$m$	Mass	18	g
	Standards	EN 50178: 1997	

## Application Domain

- Industrial.

- Notes:**
- <sup>1)</sup> Measuring range limited to  $\pm 60 \text{ A}_{max}$
  - <sup>2)</sup> Measuring range limited to  $\pm 55 \text{ A}_{max}$
  - <sup>3)</sup> Result of the coercive field of the magnetic circuit.

## Dimensions LA 55-P (in mm. 1 mm = 0.0394 inch)

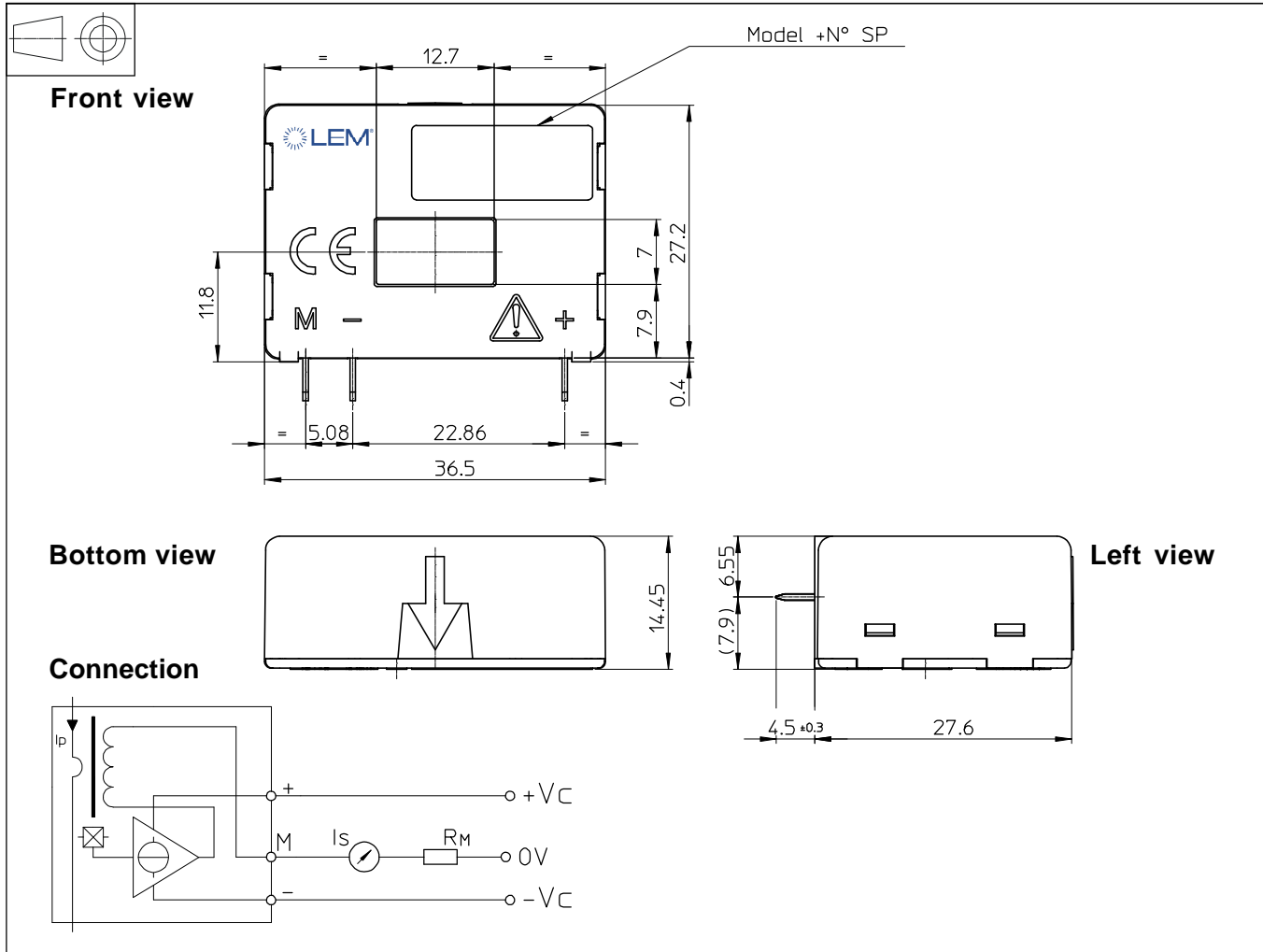

### Mechanical characteristics

- General tolerance  $\pm 0.2$  mm
  - Primary through-hole 12.7 x 7 mm
  - Fastening & connection of secondary 3 pins  
0.63 x 0.56mm  
0.9 mm
- Recommended PCB hole

### Remarks

- $I_s$  is positive when  $I_p$  flows in the direction of the arrow.
- Temperature of the primary conductor should not exceed 90°C.
- Dynamic performances (di/dt and response time) are best with a single bar completely filling the primary hole.
- In order to achieve the best magnetic coupling, the primary windings have to be wound over the top edge of the device.
- This is a standard model. For different versions (supply voltages, turns ratios, unidirectional measurements...), please contact us.

### Safety



This transducer must be used in electric/electronic equipment with respect to applicable standards and safety requirements in accordance with the manufacturer's operating instructions.



Caution, risk of electrical shock

When operating the transducer, certain parts of the module can carry hazardous voltage (eg. primary busbar, power supply).

Ignoring this warning can lead to injury and/or cause serious damage.

This transducer is a built-in device, whose conducting parts must be inaccessible after installation.

A protective housing or additional shield could be used.

Main supply must be able to be disconnected.